

Optimum Growth® Integrated Lid for 6-Well Plate Technical Data Sheet

Product Description	Part #	Sterility
Optimum Growth® Integrated Lid for 6-Well Plate	981648	10 ⁻⁶

OptimumGrowth®

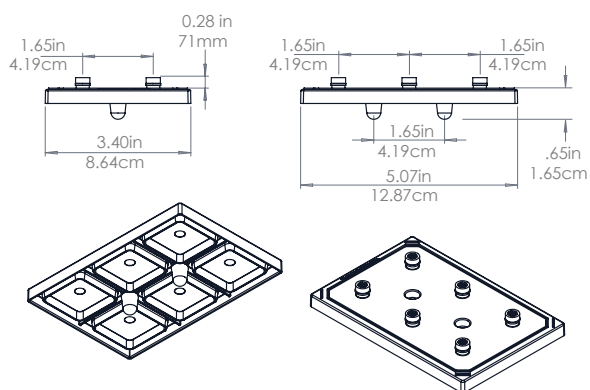

Introduction

Optimum Growth® integrated lid for use on 6-Well Optimum Growth® 6-Well Plate

Specifications

Well Count	6
Plate Compatibility	931167
Membrane	PTFE
Pore Size	0.2µm
Sterility (SAL)	10 ⁻⁶

6-Well Plate Lid Guidance Table:

Lid Type	Preferred Top	Fill Volume	Shake Speed	Culture Duration
Acrylic lid (included with P/N 931167)	Least Recommended	20-30mL	180-200RPM	4-7 (Days)
6-Well Integrated Lid (P/N 981648)	Highly recommended	20-30mL 20-50mL	200-225RPM 200-225RPM	4-7 (Days) 7-10 (Days)
Airporous Plate Seal (P/N 899410)	Recommended	20-30mL	180-200RPM	1-3 (Days)

Note: This is applicable for cell types: CHO, HEK, & Insect

FAQ's

What provides gas exchange to the well plate from the Integrated Lid (Part# 981648)?

Although the lid incorporates inner ridges to individually seal each well, it is equipped with six 0.2 µm PTFE membranes positioned over the center of each well. These membranes facilitate gas exchange that is enhanced by orbital agitation during culture.

How does the Integrated Lid (Part# 981648) help in low humidity environments?

The strategic placement and optimized size of the 0.2 µm PTFE membranes significantly reduce evaporative volume loss by minimizing the surface area exposed to low humidity conditions. This design feature enables extended experimental durations at fill volumes of 20-50 mL, as detailed in the 6-Well Plate Lid Guidance Table.

How does the Integrated Lid (Part# 981648) increase the working volume of the 6-Well Plate?

The lid features precision-engineered inner ridges that create an effective seal for each well, thereby containing any droplets that would otherwise escape at volumes exceeding 30 mL. The lid has been validated for maximum volumes of 50 mL in both mammalian and insect cell culture applications.

Can I spin my 6-Well Plate in a standard centrifuge?

The combined height of the plate with installed lid (either Integrated or Acrylic) is 3.49 in / 8.86 cm, compatible with most swinging bucket rotors designed for deep well plates. The plate assembly can withstand centrifugation up to 2000g. For detailed dimensional specifications or if technical drawings are required, please contact www.technicalsupport.com or your local Sales Representative.

How many plates can I put in a standard shaker at one time?

The 6-Well Plate demonstrates universal compatibility with INFORS™ sticky mats and Kuhner™ spring trays. The INFORS™ Sticky Mat System (Part# 78113) securely accommodates up to 24 6-Well Plates per tray on standard INFORS™ Multitron platforms. The Kuhner™ Spring Tray F System (Part# 104825) utilizes a spring-loaded mechanism that securely holds 24 6-Well Plates per tray.

Are the 6-Well Lids single-use?

Yes, the Optimum Growth® 6-Well Lids are designed for single-use and are not autoclavable.

Why do Optimum Growth® plates perform better than standard bioreactor tubes?

6-Well Plates are amenable to automated systems and manual benchtop operations. Utilizing the 6-Well Plate format reduces contamination risks by minimizing the number of individual vessels requiring handling during experimental procedures.

Why do Optimum Growth® plates perform better than other disposable plates?

The 6-Well Plate represents the only mid-scale format that integrates with its dedicated Integrated Lid system. This eliminates the need for bulky clamping mechanisms to secure the plate or maintain lid placement during operation.

Thomson Instrument Company is not affiliated with INFORS™ and Kuhner™